

# SanTRAL® HAU 1

automatic paper towel dispenser  
for standard paper rolls • free choosable products  
lockable

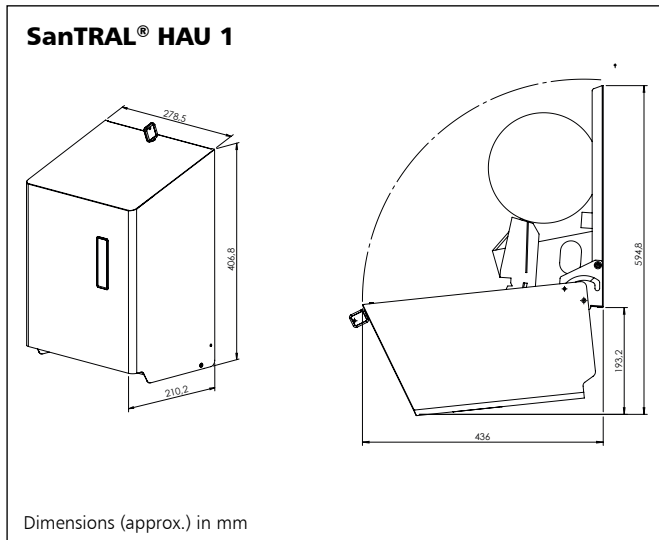

## Automatic paper towel dispenser

- References:
- ▶ for standard paper rolls
  - ▶ old people's-/nursing homes, hospitals, laboratories, large kitchens, food industry, industry, shopping centers, gastronomy and hotels, airports, penal institutions, schools, sport facilities, administrations

### Place of application:

- ▶ washrooms, toilets, baths, care and medical rooms, kitchens, production sites, offices

## Technical Data

- Housing: Stainless steel, brushed with Anti-Fingerprint-Coating or powder coated white (RAL 9010)
- Window: Plastic, clear
- Lock: Plastic (antivandalism function)
- Key: Plastic
- Wall mounting: with four rawl plugs and stainless steel screws
- Batteries: operated with 4 'D' type batteries for a total of 6.0 Volts
- Max. roll width: 200 mm
- Max. roll diameter: 190 mm
- Min. inside diameter for paper withdrawal: 38 mm

## Description for tender

..... pcs. **SanTRAL® HAU 1 E Art.-No. 1418109**  
automatic paper towel dispenser, for standard paper rolls, stainless steel, brushed with Anti-Fingerprint-Coating, a new paper towel is automatically dispensed after a towel is removed, stainless steel withdrawal, special lock (antivandalism function), window for monitoring filling level, housing diagonal surfaces impede the placement of foreign bodies  
Dimensions W 279 x H 406 x D 210 mm

..... pcs. **SanTRAL® HAU 1 P Art.-No. 1418110**  
automatic paper towel dispenser, for standard paper rolls, stainless steel, powder coated white (RAL 9010), a new paper towel is automatically dispensed after a towel is removed, stainless steel withdrawal, special lock (antivandalism function), window for monitoring filling level, diagonal surfaces impede the placement of foreign bodies  
Dimensions W 279 x H 406 x D 210 mm

Product: **SanTRAL®**  
Manufacturer: OPHARDT HYGIENE-TECHNIK GmbH + Co. KG