

ELSX 26 A - TLSX 26 A

Soap-/disinfectant dispenser for disposable bottles as well as refillable containers, aluminium housing, extra long operating lever, 500 ml or 1000 ml

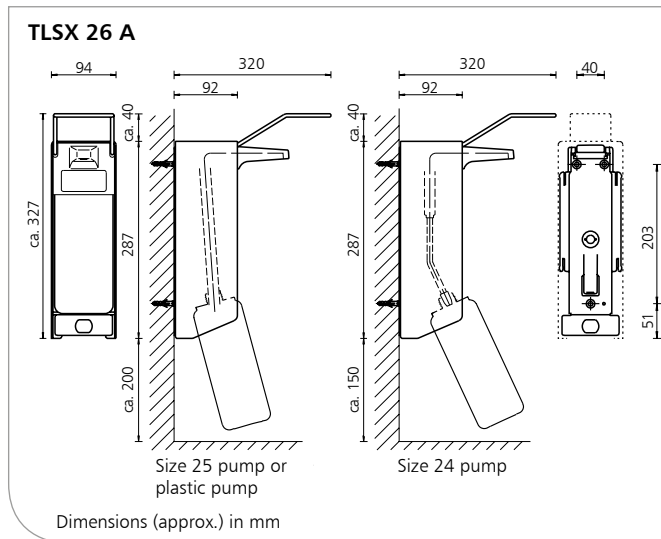
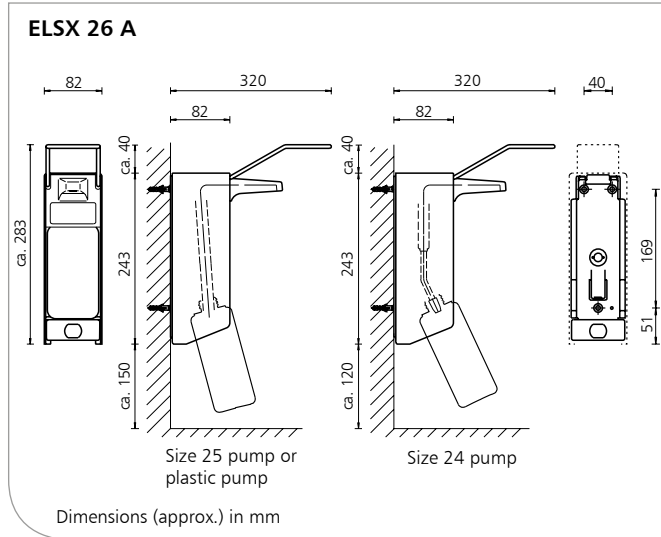

Product characteristics

- ▶ Dispenser for liquid soaps, detergents, alcoholic hand disinfectants, lotions, etc.
- ▶ For 500 ml or 1000 ml disposable bottles as well as refillable containers
- ▶ With replaceable pump
- ▶ With locking plate
- ▶ Incl. mounting kit for three-point wall mounting

Interesting information

References: ▶ Clinics, doctors' practices, health and care facilities, laboratories, rescue stations, commercial kitchens, foodstuffs industry

Application examples: ▶ Particularly well suited to areas where hand hygiene is critical and in medical and food processing areas

Technical data

- Housing: Aluminium, anodised matt silver
- Dosing pump: Size 25 pump, stainless steel, straight suction tube, size 24 pump, stainless steel, cranked suction tube, 25+24 pumps autoclavable up to 121°C, 2 bar
- Dispensing quantity: Dispensing quantity adjustable to ca. 0.7 ml/1.0 ml/1.5 ml (depending on the viscosity of the filling material)
- Operating lever: Stainless steel
- Wall plate: Standard ingo-man® plastic wall plate
- Labelling clip: White (for product differentiation)
- Wall mounting: Wall mounting with 3 screws and wall plugs
- Cleaning: Dispenser and standard pump dishwasher-safe and autoclavable up to 134° C, 2 bar

Description for tender - see overleaf

ELSX 26 A - TLSX 26 A/0320/1.2



Subject to technical modifications.
Tests are required before new filling materials are used!



Ophardt Hygiene-Technik GmbH + Co. KG

Lindenau 27 | 47661 Issum | Germany
Tel.: +49 (0) 28 35 18-10 | Fax +49 (0) 28 35 18-77
planer@ophardt.com | www.ophardt.com

ELSX 26 A - TLSX 26 A

Soap-/disinfectant dispenser for disposable bottles as well as refillable containers, aluminium housing, extra long operating lever, 500 ml or 1000 ml

Description for tender

ingo-man® classic ELSX 26 A/24
Art. No. 1411023
... Pcs. Soap-/disinfectant dispenser, 500 ml, suitable for standard disposable bottles as well as refillable containers, matt silver anodised aluminium housing, extra long stainless steel operating lever, with identification clip, incl. empty bottle, replaceable size 24 stainless steel pump, pump can be quickly and simply removed from the rear of the dispenser for cleaning without mounting tools - can be put back into service in reverse order with "push and click" system, autoclavable and dishwasher-safe
Dimensions: W 82 x H 283 x D 320 mm

ingo-man® classic ELSX 26 A/25
Art. No. 1411024
... Pcs. Soap-/disinfectant dispenser, 500 ml, suitable for standard disposable bottles as well as refillable containers, matt silver anodised aluminium housing, extra long stainless steel operating lever, with identification clip, incl. empty bottle, replaceable size 25 stainless steel pump, pump can be quickly and simply removed from the rear of the dispenser for cleaning without mounting tools - can be put back into service in reverse order with "push and click" system, autoclavable and dishwasher-safe
Dimensions: W 82 x H 283 x D 320 mm

ingo-man® classic TLSX 26 A/24
Art. No. 1410997
... Pcs. Soap-/disinfectant dispenser, 1000 ml, suitable for standard disposable bottles as well as refillable containers, matt silver anodised aluminium housing, extra long stainless steel operating lever, with identification clip, incl. empty bottle, replaceable size 24 stainless steel pump, pump can be quickly and simply removed from the rear of the dispenser for cleaning without mounting tools - can be put back into service in reverse order with "push and click" system, autoclavable and dishwasher-safe
Dimensions: W 94 x H 327 x D 320 mm

ingo-man® classic TLSX 26 A/25
Art. No. 1410864
... Pcs. Soap-/disinfectant dispenser, 1000 ml, suitable for standard disposable bottles as well as refillable containers, matt silver anodised aluminium housing, extra long stainless steel operating lever, with identification clip, incl. empty bottle, replaceable size 25 stainless steel pump, pump can be quickly and simply removed from the rear of the dispenser for cleaning without mounting tools - can be put back into service in reverse order with "push and click" system, autoclavable and dishwasher-safe
Dimensions: W 94 x H 327 x D 320 mm

Product:
Manufacturer:

ingo-man® classic
OPHARDT HYGIENE-TECHNIK GmbH + Co. KG