

CPU 2L (soap dispenser left)

Combination dispenser for liquid soaps (S), disinfectants (D) or foam soaps (F) and folded paper towels, stainless steel (AFP) or powder-coated, 1200 ml, approx. 500 - 600 sheets

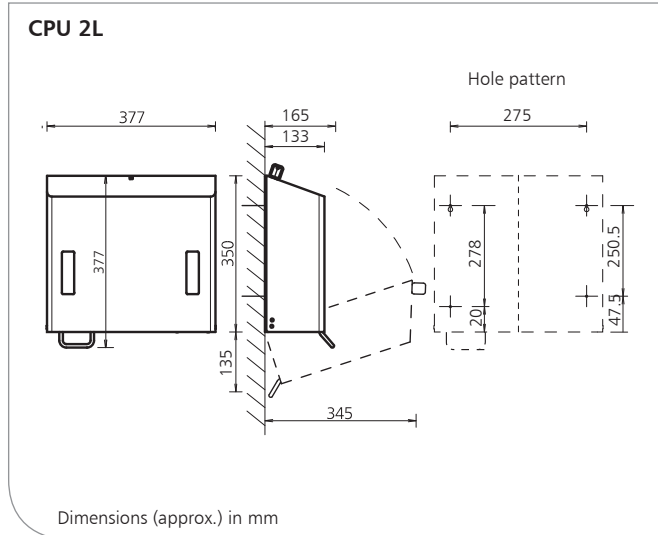

Product characteristics

- ▶ Dispenser for dosing liquid soaps and disinfectants (S), low-viscosity hand disinfectants with spray pump (D) or foam soap (F) as well as folded paper towels
- ▶ Refillable container with 1200 ml volume plus overflow quantity
- ▶ Available in right-handed or left-handed form
- ▶ Folded paper capacity approx. 500-600 sheets
- ▶ Housing with sloped lid to prevent foreign objects being placed on the dispenser
- ▶ High-quality and robust stainless steel housing
- ▶ Hygienic and easy-to-clean stainless steel operating lever
- ▶ Hygienic removal – hand contact only with the paper towel
- ▶ Plastic lock with anti-vandalism function
- ▶ Modular system with replaceable container/pump unit, for liquid soaps and disinfectants (S), low-viscosity hand disinfectants with spray pump (D) or foam soap (F)
- ▶ Dispensing quantity approx. 0.7 ml/stroke (D spray pump), approx. 0.7 ml/stroke (F foam pump), approx. 1.5 ml/stroke (S soap pump)
- ▶ Easily filled from above
- ▶ Open without wall contact
- ▶ Container easily removed for cleaning
- ▶ Viewing window for monitoring filling level
- ▶ Incl. mounting kit for four-point wall mounting

Interesting information

References:

- ▶ Conference centres, exhibitions, airports, train stations, catering, retirement/care homes, hospitals, laboratories, commercial kitchen, food processing, industry, shopping centres, hotels, correctional facilities, schools, kindergartens, sports centres, administration facilities

Application examples:

- ▶ Washrooms, toilets, baths, care and examination rooms, kitchens, entrance areas

Technical data

Housing:

Stainless steel AISI 304, brushed with Anti-Fingerprint-Coating (AFP), powder-coated white (RAL 9010) or powder-coated matte black (RAL 9005)

Viewing window:

Transparent plastic

Dosing pump:

For liquid soaps and disinfectants (S), low-viscosity hand disinfectants with spray pump (D) or foam soap (F), dispensing quantity approx. 0.7 (D) – 0.7 (F) – 1.5 (S) ml/stroke

Operating lever:

Stainless steel AISI 304

Lock:

Vandalism-proof lock, plastic

Wall mounting:

Wall mounting with 4 screws and wall plugs

Weight:

4,080 kg

Description for tender - see overleaf

CPU 2 L/0121/2.0



Subject to technical modifications.
Product compatibility testing required before new filling materials are used!



OPHARDT HYGIENE-TECHNIK GmbH + Co. KG
Lindenau 27 | 47661 Issum | Germany
Tel.: +49 (0) 28 35 18-10 | Fax +49 (0) 28 35 18-77
planer@ophardt.com | www.ophardt.com

CPU 2L (soap dispenser left)

Combination dispenser for liquid soaps (S), disinfectants (D) or foam soaps (F) and folded paper towels, stainless steel (AFP) or powder-coated, 1200 ml, approx. 500 - 600 sheets

Description for tender

... Pcs. **SanTRAL® Classic CPU 2L E/S Steel Touch (ST)**
Art. No. 1419953
Compact dispenser combination for liquid soaps (1200 ml), and standard folded paper towels (approx. 500 - 600 sheets), soap dispenser on the left, brushed stainless steel housing with Ophardt Hygiene Anti-Fingerprint-Coating (AFP), stainless steel back plate, stainless steel operating lever, press-actuation, plastic paper withdrawal, with vandalism-proof lock, viewing window for monitoring filling level, removable refillable container, free choice of manufacturers for refill materials, housing with sloped lid to prevent foreign objects being placed on the dispenser
Dimensions: W 377 x H 377 x D 165 mm

... Pcs. **SanTRAL® Classic CPU 2L E/F Steel Touch (ST)**
Art. No. 1419954
Compact combination dispenser for foam soaps (1200 ml), and standard folded paper towels (approx. 500 - 600 sheets), foam soap dispenser on the left, brushed stainless steel housing with Ophardt Hygiene Anti-Fingerprint-Coating (AFP), stainless steel back plate, stainless steel operating lever, press-actuation, plastic paper withdrawal, with vandalism-proof lock, viewing window for monitoring filling level, removable refillable container, free choice of manufacturers for refill materials, housing with sloped lid to prevent foreign objects being placed on the dispenser
Dimensions: W 377 x H 377 x D 165 mm

... Pcs. **SanTRAL® Classic CPU 2L E/D Steel Touch (ST)**
Art. No. 1419955
Compact combination dispenser for disinfectant with spray pump (1200 ml) and standard folded paper towels (approx. 500 - 600 sheets), disinfectant dispenser on the left, brushed stainless steel housing with Ophardt Hygiene Anti-Fingerprint-Coating (AFP), stainless steel back plate, stainless steel operating lever, press-actuation, plastic paper withdrawal, with vandalism-proof lock, viewing window for monitoring filling level, removable refillable container, free choice of manufacturers for refill materials, housing with sloped lid to prevent foreign objects being placed on the dispenser
Dimensions: W 377 x H 377 x D 165 mm

Additional models:

for liquid soaps:

CPU 2L P/S Ivory White (IW), white RAL 9010 Art. No. 1419956
CPU 2L P/S Midnight (MN), matte black RAL 9005 Art. No. 1423143

for foam soaps:

CPU 2L P/F Ivory White (IW), white RAL 9010 Art. No. 1419957
CPU 2L P/F Midnight (MN), matte black RAL 9005 Art. No. 1423144

with spray pump for dosing of disinfectants:

CPU 2L P/D Ivory White (IW), white RAL 9010 Art. No. 1419958
CPU 2L P/D Midnight (MN), matte black RAL 9005 Art. No. 1423145

Additional RAL Classic colours available upon request.

Compatible accessories

► Drip tray SH NSU (mounted with dispenser):
Art. No. 1420578

Product: **SanTRAL® Classic**
Manufacturer: OPHARDT HYGIENE-TECHNIK GmbH + Co. KG