

### IMP Touchless

Soap-/disinfectant dispenser for disposable bottles as well as refillable containers and hygiene packages, aluminium or stainless steel housing, touchless operation, 500 ml or 1000 ml

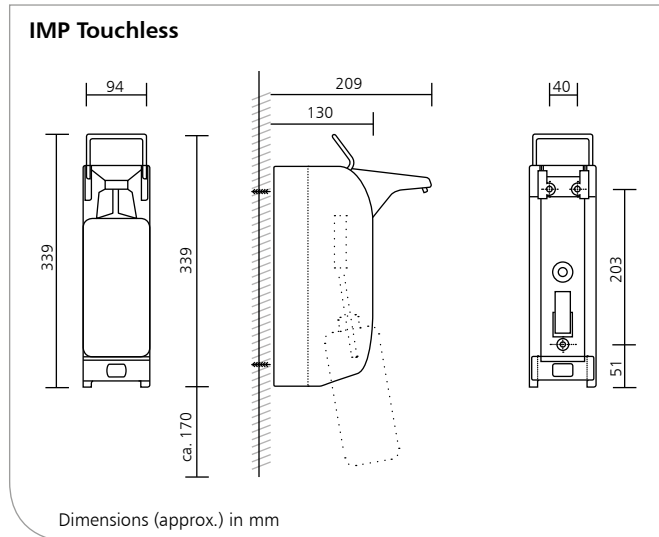

#### Product characteristics

- ▶ Touchless dispenser for alcoholic hand disinfectants, liquid soaps, lotions, etc.
- ▶ For 500 ml or 1000 ml disposable bottles as well as refillable containers and hygiene packages
- ▶ Pivoting face shield for simple pump replacement from the front without having to remove the dispenser from the wall
- ▶ Incl. mounting kit for three-point wall mounting

#### Interesting information

References: ▶ Clinics, doctors' practices, health and care facilities, laboratories, rescue stations, commercial kitchens, foodstuffs industry

Application examples: ▶ Particularly well suited to areas where hand hygiene is critical and in medical and food processing areas

#### Technical data

- Housing: Aluminium, anodised matt silver or brushed stainless steel
- Dosing pump: DHP disposable hygiene pump, made with recyclable plastic (standard pump, for other pumps see overleaf)
- Dispensing quantity: 1.5 ml/stroke (depending on the viscosity of the filling material)
- Emergency bar: Stainless steel
- Wall mounting: Wall mounting with 3 screws and wall plugs
- Batteries: 5 type 'D' single-cell

Description for tender - see overleaf

IMP Touchless/04/20/2.2



Subject to technical modifications.  
Tests are required before new filling materials are used!



OPHARDT HYGIENE-TECHNIK GmbH + Co. KG  
Lindenau 27 | 47661 Issum | Germany  
Tel.: +49 (0) 28 35 18-10 | Fax +49 (0) 28 35 18-77  
planer@ophardt.com | www.ophardt.com

# IMP Touchless

Soap-/disinfectant dispenser for disposable bottles as well as refillable containers and hygiene packages, aluminium or stainless steel housing, touchless operation, 500 ml or 1000 ml

## Description for tender

... Pcs. **ingo-man® plus IMP T A DHP Touchless Art. No. 4402152**  
Soap-/disinfectant dispenser, 1000 ml, suitable for standard disposable bottles, refillable containers and hygiene packages, matt silver anodised aluminium housing, incl. 5 alkaline "D" batteries, touchless, 2 proximity sensors, triggering of the pump mechanism from above and below the pump outlet, recyclable disposable pump, plastic, pump can be quickly and simply removed through front removal  
Dimensions: W 94 x H 339 x D 209 mm

... Pcs. **ingo-man® plus IMP T A Touchless Art. No. 1415524**  
Soap-/disinfectant dispenser, 1000 ml, suitable for standard disposable bottles, refillable containers and hygiene packages, matt silver anodised aluminium housing, incl. empty bottle and 5 alkaline "D" batteries, touchless, 2 proximity sensors, triggering of the pump mechanism from above and below the pump outlet, autoclavable and dishwasher-safe, replaceable stainless steel pump, pump can be quickly and simply removed for cleaning through front removal - can be put back into service in reverse order with "push and click" system  
Dimensions: W 94 x H 339 x D 209 mm

... Pcs. **ingo-man® plus IMP E A DHP Touchless Art. No. 4402148**  
Soap-/disinfectant dispenser, 500 ml, suitable for standard disposable bottles, refillable containers and hygiene packages, matt silver anodised aluminium housing, incl. 5 alkaline "D" batteries, touchless, 2 proximity sensors, triggering of the pump mechanism from above and below the pump outlet, recyclable disposable pump, plastic, pump can be quickly and simply removed through front removal  
Dimensions: W 94 x H 339 x D 209 mm

... Pcs. **ingo-man® plus IMP E A Touchless Art. No. 1415523**  
Soap-/disinfectant dispenser, 500 ml, suitable for standard disposable bottles, refillable containers and hygiene packages, matt silver anodised aluminium housing, incl. empty bottle and 5 alkaline "D" batteries, touchless, 2 proximity sensors, triggering of the pump mechanism from above and below the pump outlet, autoclavable and dishwasher-safe, replaceable stainless steel pump, pump can be quickly and simply removed for cleaning through front removal - can be put back into service in reverse order with "push and click" system  
Dimensions: W 94 x H 339 x D 209 mm

**ingo-man® plus IMP T E DHP Touchless Art. No. 4402154**  
Soap-/disinfectant dispenser, 1000 ml, suitable for standard disposable bottles, refillable containers and hygiene packages, polished stainless steel housing, incl. 5 alkaline "D" batteries, touchless, 2 proximity sensors, triggering of the pump mechanism from above and below the pump outlet, recyclable disposable pump, plastic, pump can be quickly and simply removed through front removal  
Dimensions: W 94 x H 339 x D 209 mm

**ingo-man® plus IMP T E Touchless Art. No. 1417071**  
Soap-/disinfectant dispenser, 1000 ml, suitable for standard disposable bottles, refillable containers and hygiene packages, polished stainless steel housing, incl. empty bottle and 5 alkaline "D" batteries, touchless, 2 proximity sensors, triggering of the pump mechanism from above and below the pump outlet, autoclavable and dishwasher-safe, replaceable stainless steel pump, pump can be quickly and simply removed for cleaning through front removal - can be put back into service in reverse order with "push and click" system  
Dimensions: W 94 x H 339 x D 209 mm

**ingo-man® plus IMP E E DHP Touchless Art. No. 4402150**  
Soap-/disinfectant dispenser, 500 ml, suitable for standard disposable bottles, refillable containers and hygiene packages, polished stainless steel housing, incl. 5 alkaline "D" batteries, touchless, 2 proximity sensors, triggering of the pump mechanism from above and below the pump outlet, recyclable disposable pump, plastic, pump can be quickly and simply removed through front removal  
Dimensions: W 94 x H 339 x D 209 mm

**ingo-man® plus IMP E E Touchless Art. No. 1417728**  
Soap-/disinfectant dispenser, 500 ml, suitable for standard disposable bottles, refillable containers and hygiene packages, polished stainless steel housing, incl. empty bottle and 5 alkaline "D" batteries, touchless, 2 proximity sensors, triggering of the pump mechanism from above and below the pump outlet, autoclavable and dishwasher-safe, replaceable stainless steel pump, pump can be quickly and simply removed for cleaning through front removal - can be put back into service in reverse order with "push and click" system  
Dimensions: W 94 x H 339 x D 209 mm

Product:  
Manufacturer:

**ingo-man® plus**  
OPHARDT HYGIENE-TECHNIK GmbH + Co. KG