

IMP Touchless Mains Operated

Soap-/disinfectant dispenser for disposable bottles as well as refillable containers and hygiene packages, aluminium or stainless steel housing, touchless operation, with mains operated, 500 ml or 1000 ml

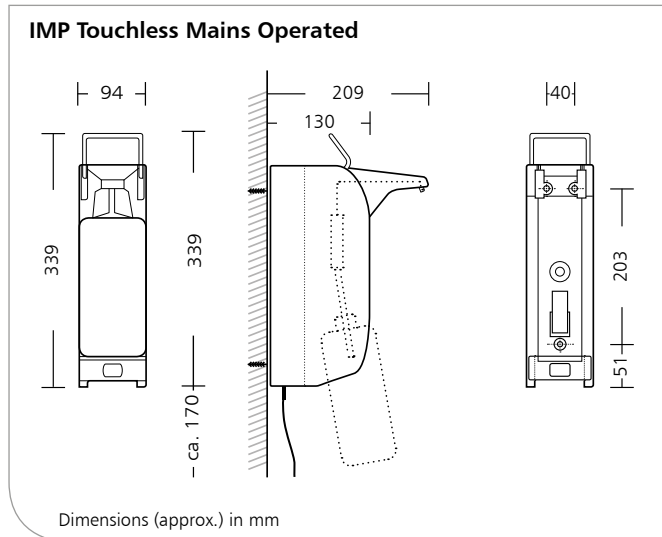

Product characteristics

- ▶ Touchless dispenser for alcoholic hand disinfectants, liquid soaps, lotions, etc.
- ▶ For 500 ml or 1000 ml disposable bottles as well as refillable containers and hygiene packages
- ▶ With mains operated
- ▶ Pivoting face shield for simple pump replacement from the front without having to remove the dispenser from the wall
- ▶ Incl. mounting kit for four-point wall mounting

Interesting information

References: ▶ Clinics, doctors' practices, health and care facilities, rescue stations, food processing and preparation

Application examples: ▶ Particularly well suited to toilets and washrooms in public and semi-public buildings

Technical data

- Housing: Aluminium, anodised matt silver or brushed stainless steel
- Dosing pump: DHP disposable hygiene pump, made with recyclable plastic (standard pump, for other pumps see overleaf)
- Dispensing quantity: 1.5 ml/stroke (depending on the viscosity of the filling material)
- Emergency bar: Stainless steel
- Wall mounting: Wall mounting with 4 screws and wall plugs
- Mains operated: External mains power unit, transformer, (W 120 x H 60 x D 35 mm),
Input: 100 -240 V/0.35 A, 2 m long
Output: 7.0 V/2.5 A, 1.5 m long
Plug type designation: CEE 7/17

Description for tender - see overleaf

IMP Touchless Mains Operated/0420/2.2



Subject to technical modifications.
Tests are required before new filling materials are used!



OPHARDT HYGIENE-TECHNIK GmbH + Co. KG
Lindenau 27 | 47661 Issum | Germany
Tel.: +49 (0) 28 35 18-10 | Fax +49 (0) 28 35 18-77
planer@ophardt.com | www.ophardt.com

IMP Touchless Mains Operated

Soap-/disinfectant dispenser for disposable bottles as well as refillable containers and hygiene packages, aluminium or stainless steel housing, touchless operation, with mains operated, 500 ml or 1000 ml

Description for tender

... Pcs. **ingo-man® plus IMP T A DHP Touchless mains operated Art. No. 4402153** ... Pcs.
Soap-/disinfectant dispenser, 1000 ml, suitable for standard disposable bottles, refillable containers and hygiene packages, matt silver anodised aluminium housing, mains operated, touchless, 2 proximity sensors, triggering of the pump mechanism from above and below the pump outlet, recyclable disposable pump, plastic, pump can be quickly and simply removed through front removal
Dimensions: W 94 x H 339 x D 209 mm

... Pcs. **ingo-man® plus IMP T A Touchless mains operated Art. No. 1418061** ... Pcs.
Soap-/disinfectant dispenser, 1000 ml, suitable for standard disposable bottles, refillable containers and hygiene packages, matt silver anodised aluminium housing, incl. empty bottle, mains operated, touchless, 2 proximity sensors, triggering of the pump mechanism from above and below the pump outlet, autoclavable and dishwasher-safe, replaceable stainless steel pump, pump can be quickly and simply removed for cleaning through front removal - can be put back into service in reverse order with "push and click" system
Dimensions: W 94 x H 339 x D 209 mm

... Pcs. **ingo-man® plus IMP E A DHP Touchless mains operated Art. No. 4402149** ... Pcs.
Soap-/disinfectant dispenser, 500 ml, suitable for standard disposable bottles, refillable containers and hygiene packages, matt silver anodised aluminium housing, mains operated, touchless, 2 proximity sensors, triggering of the pump mechanism from above and below the pump outlet, recyclable disposable pump, plastic, pump can be quickly and simply removed through front removal
Dimensions: W 94 x H 339 x D 209 mm

... Pcs. **ingo-man® plus IMP E A Touchless mains operated Art. No. 1417545** ... Pcs.
Soap-/disinfectant dispenser, 500 ml, suitable for standard disposable bottles, refillable containers and hygiene packages, matt silver anodised aluminium housing, incl. empty bottle, mains operated, touchless, 2 proximity sensors, triggering of the pump mechanism from above and below the pump outlet, autoclavable and dishwasher-safe, replaceable stainless steel pump, pump can be quickly and simply removed for cleaning through front removal - can be put back into service in reverse order with "push and click" system
Dimensions: W 94 x H 339 x D 209 mm

ingo-man® plus IMP T E DHP Touchless mains operated Art. No. 4402155
Soap-/disinfectant dispenser, 1000 ml, suitable for standard disposable bottles, refillable containers and hygiene packages, brushed stainless steel housing, mains operated, touchless, 2 proximity sensors, triggering of the pump mechanism from above and below the pump outlet, recyclable disposable pump, plastic, pump can be quickly and simply removed through front removal
Dimensions: W 94 x H 339 x D 209 mm

ingo-man® plus IMP T E Touchless mains operated Art. No. 1417544
Soap-/disinfectant dispenser, 1000 ml, suitable for standard disposable bottles, refillable containers and hygiene packages, brushed stainless steel housing, incl. empty bottle, mains operated, touchless, 2 proximity sensors, triggering of the pump mechanism from above and below the pump outlet, autoclavable and dishwasher-safe, replaceable stainless steel pump, pump can be quickly and simply removed for cleaning through front removal - can be put back into service in reverse order with "push and click" system
Dimensions: W 94 x H 339 x D 209 mm

ingo-man® plus IMP E E DHP Touchless mains operated Art. No. 4402151
Soap-/disinfectant dispenser, 500 ml, suitable for standard disposable bottles, refillable containers and hygiene packages, brushed stainless steel housing, mains operated, touchless, 2 proximity sensors, triggering of the pump mechanism from above and below the pump outlet, recyclable disposable pump, plastic, pump can be quickly and simply removed through front removal
Dimensions: W 94 x H 339 x D 209 mm

ingo-man® plus IMP E E Touchless mains operated Art. No. 1417727
Soap-/disinfectant dispenser, 500 ml, suitable for standard disposable bottles, refillable containers and hygiene packages, brushed stainless steel housing, incl. empty bottle, mains operated, touchless, 2 proximity sensors, triggering of the pump mechanism from above and below the pump outlet, autoclavable and dishwasher-safe, replaceable stainless steel pump, pump can be quickly and simply removed for cleaning through front removal - can be put back into service in reverse order with "push and click" system
Dimensions: W 94 x H 339 x D 209 mm

Product:
Manufacturer:

ingo-man® plus
OPHARDT HYGIENE-TECHNIK GmbH + Co. KG