

IMS ELS A

Soap-/disinfectant dispenser for 500 ml Euro bottles, aluminum housing, long operating lever, with "intelligent" face shield (ingo-man® SmartNose)

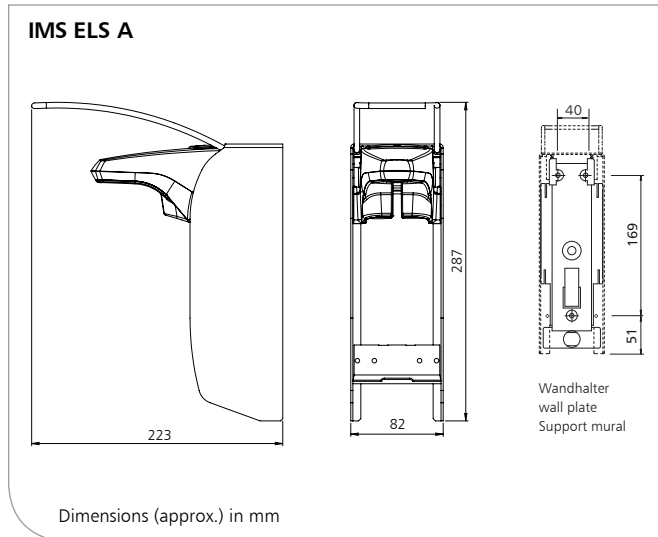

Product characteristics

- ▶ Dispenser for liquid soaps without grit, alcoholic hand disinfectants, lotions, etc.
- ▶ For 500 ml Euro bottles as well as refillable containers and hygiene packages
- ▶ With long operating lever
- ▶ For different pump types
- ▶ Pivoting face shield for simple pump replacement from the front without having to remove the dispenser from the wall
- ▶ Incl. mounting kit for three-point wall mounting with ingo-man® standard back plate
- ▶ With ingo-man® SmartNose for fully automatic and continuous monitoring of the hand hygiene compliance
- ▶ With integrated Feedback-LED: gives immediate feedback when the required dosage has been dispensed (standard: 3 ml)
- ▶ With integrated "Low-Battery-Level"-LED: indicates when approx. 10% of the capacity is still available
- ▶ Optimized for connection to the OPHARDT Hygiene Monitoring System® (OHMS) to analyze hand hygiene compliance

Interesting information

References: ▶ Hospitals, clinics, dental practices, retirement and nursing homes, medical facilities, hygiene-sensitive areas

Areas of Application:

- ▶ Intensive care units, general wards, surgery areas, entrance areas, nursing rooms, washrooms, sanitary rooms

Technical data dispenser

Housing: Aluminum, anodized matte silver
 Dosing pump: DHP disposable hygiene pump, made with recyclable plastic (standard pump, for other pumps see overleaf)
 Dispensing quantity: 1.5 ml/stroke (depending on the viscosity of the filling material)
 Operating lever: Stainless steel
 Wall plate: Standard ingo-man® plastic wall plate
 Wall mounting: Wall mounting with 3 screws and wall plugs
 Cleaning: Dispenser housing - after removing of the face shield - and stainless steel pumps dishwasher-safe and autoclavable to 134°C, 2 bar

Technical data ingo-man® SmartNose

Housing: Plastic: ABS (Acrylonitrile butadiene styrene), Polycarbonate
 Inner component: Board with sensors and WiFi module 802.11 b/g (WPA and WPA2)
 Firmware: Comfortable updates "over-the-air" (OTA)
 Battery: Lithium battery ER26500 (Transport Code: 3091; Hazardous material class: 9), 3.6 V, 9.0 Ah, exchangeable, non-rechargeable, confected battery with cable and plug can be reordered

Description for tender - see overleaf

Subject to technical modifications.
 Tests are required before new filling materials are used!



OPHARDT HYGIENE-TECHNIK GmbH + Co. KG
 Lindenau 27 | 47661 Issum | Germany
 Tel.: +49 (0) 28 35 18-10 | Fax +49 (0) 28 35 18-77
 planer@ophardt.com | www.ophardt.com

IMS ELS A

Soap-/disinfectant dispenser for 500 ml Euro bottles, aluminum housing, long operating lever, with "intelligent" face shield (ingo-man® SmartNose)

Description for tender

... Pcs. **ingo-man® smart IMS ELS A/DHP**
Art. No. 4402651
Dispenser for hand disinfectants, soaps and lotions, for 500 ml standard Euro bottles, long operating stainless steel lever, matte-silver anodized aluminum housing, incl. DHP single use plastic pump, dosage 1.5 ml/stroke, easy pump replacement through front removal, with intelligent face shield that enables WiFi communication with the OPHARDT Hygiene Monitoring System® (OHMS), the unit automatically records hand hygiene events and sends that data to a central database for evaluation, gives immediate feedback on performance through an integrated LED, A separate integrated LED informs users when the battery is low
Dimensions: W 82 x H 287 x D 223 mm

... Pcs. **ingo-man® smart IMS ELS A/24**
Art. No. 4402648
Soap and disinfectant dispenser, for 500 ml standard Euro bottles, long operating stainless steel lever, matte-silver anodized aluminum housing, exchangeable stainless steel pump 24 with bent suction tube, different dosage adjustments (approx. 0.75/ 1.0/ 1.2/ 1.5 ml/stroke), 1 bottle HDPE, easy pump replacement through front removal, with intelligent face shield that enables WiFi communication with the OPHARDT Hygiene Monitoring System® (OHMS), the unit automatically records hand hygiene events and sends that data to a central database for evaluation, gives immediate feedback on performance through an integrated LED, A separate integrated LED informs users when the battery is low
Dimensions: W 82 x H 287 x D 223 mm

... Pcs. **ingo-man® smart IMS ELS A/25**
Art. No. 4402650
Soap and disinfectant dispenser, for 500 ml standard Euro bottles, long operating stainless steel lever, matte-silver anodized aluminum housing, exchangeable stainless steel pump 25 with straight suction tube, different dosage adjustments (approx. 0.75/ 1.0/ 1.2/ 1.5 ml/stroke), 1 bottle HDPE, easy pump replacement through front removal, with intelligent face shield that enables WiFi communication with the OPHARDT Hygiene Monitoring System® (OHMS), the unit automatically records hand hygiene events and sends that data to a central database for evaluation, gives immediate feedback on performance through an integrated LED, A separate integrated LED informs users when the battery is low
Dimensions: W 82 x H 287 x D 223 mm

... Pcs. **ingo-man® smart IMS ELS A/K**
Art. No. 4402654
Soap and disinfectant dispenser, for 500 ml standard Euro bottles, long operating stainless steel lever, matte-silver anodized aluminum housing, exchangeable plastic pump with straight suction tube, different dosage adjustments (approx. 0.7/ 1.0/ 1.5 ml/stroke), 1 bottle HDPE, easy pump replacement through front removal, with intelligent face shield that enables WiFi communication with the OPHARDT Hygiene Monitoring System® (OHMS), the unit automatically records hand hygiene events and sends that data to a central database for evaluation, gives immediate feedback on performance through an integrated LED, A separate integrated LED informs users when the battery is low
Dimensions: W 82 x H 287 x D 223 mm

Product: **ingo-man® smart**
Manufacturer: OPHARDT HYGIENE-TECHNIK GmbH + Co. KG